

Soil temperature, humidity and conductivity three-in-one transmitter

WE-T214 User Manual



Preface

- This manual is the instruction manual about the functions, wiring methods and operation methods of the product.
- Please read this manual carefully before operation, use the product correctly to avoid unnecessary losses caused by wrong operation.
- After you have read it, please keep it in a convenient place for reference during operation.

Pay attention to

- If the contents of this manual are modified due to functional upgrades, please refer to the newly released document.
- We try to be correct in this manual. If you find any mistakes, please contact us.
- This manual is strictly prohibited from reprinting and copying.
- The final interpretation of this manual is owned by the company.

Edition

U-WES-T214-CN1 Second Edition August 2025

Confirm packaging content

After opening the packing box, please check the contents before starting operation. If you find any model or quantity error or physical damage on the appearance, please contact us.

Product packaging content is shown in the standard configuration list.

Product standard configuration list

order number	name	quantity	remarks
1	Soil temperature, humidity and conductivity three-in-one transmitter	1	
2	instructions	1	
3	antenna	1	

4	certificate	1	
---	-------------	---	--

Note: Customized products may be slightly different from standard products. Please order as the order is.

Contents

Soil temperature, humidity and conductivity three-in-one transmitter	1
Preface	1
Pay attention to	1
Edition	2
Confirm packaging content	2
.....	6
Charpter 1 Product Overview	6
1.1 Product Introduction	6
1.2 Measurement Principle	7
1.3 Product Features	8
Charpter 2 technical parameter	9
Charpter 3 Product structure and size	12
3.1 outline dimension	12
3.2 Connecting cable	13
3.3 material quality	13
Charpter 4 Installation and use	14
4.1 Inspection upon arrival	14
4.2 Installation conditions	14
4.3 Installation Notes	15

4.4 Installation indications	16
4.5 Use and maintenance	17
Chapter 5 operate	18
5.1 Display and operation unit.....	18
5.2 field operations	21
5.3 Devices on the cloud.....	24
5.4 Device local Bluetooth configuration	27
5.5 Use Notes	29
Chapter 6 Fault analysis and troubleshooting	30
Chapter 7 Warranty and after-sales service	33
Appendix Selection and ordering	34

Chapter 1 Product Overview

1.1 Product Introduction

WE - T214 is a high - performance multi - parameter transmitter specially designed for measuring soil temperature, humidity and electrical conductivity, with multiple transmission methods and flexible power supply solutions.

This device supports multiple communication technologies such as LoRa, 4G, and NB - IoT, enabling long - distance and highly reliable data transmission. The power supply method is compatible with battery power and DC24V DC power supply, which is suitable for long - term monitoring in power - free environments and can also meet the strict requirements for stable operation in industrial sites.

This transmitter has the characteristics of high sensitivity, accurate measurement, stable operation, low power consumption, strong durability, and convenient operation. It can monitor and accurately analyze the temperature, humidity and electrical

conductivity of on - site soil in real time. Through communication technologies such as LoRa, 4G, and NB, it realizes long - distance data transmission, and combines with the industrial edge computing gateway of Shidian Technology to upload data to the equipment management platform of Shidian Technology, completing real - time collection, comprehensive analysis, data storage and visualization display of multiple soil parameters.

The transmitter adopts a split structure of the main body and the probe. According to the different soil characteristics and installation conditions on site, it provides multiple installation methods and is widely used in the refined management and environmental monitoring needs of agriculture, forestry, horticultural planting and other fields.

1.2 Measurement Principle

The measurement principle of the soil temperature, humidity and electrical conductivity three - in - one transmitter is that the sensor emits a high - frequency electromagnetic wave into the soil through a transmitter, and the probe and the soil together form a capacitor to obtain the soil dielectric constant. The calibration curve stored inside the sensor converts the measured

dielectric constant value into the volumetric water content, which can accurately determine the soil moisture. The electrical conductivity is measured based on the conductivity of dissolved ions in the soil.

The soil temperature, humidity and electrical conductivity three - in - one transmitter generally consists of a soil temperature, humidity and electrical conductivity three - in - one sensor and a transmitter, connected by a cable. When the sensor collects the on - site soil temperature and electrical conductivity values, it transmits them to the transmitter through the cable.

1.3 Product Features

- Mobile APP can monitor the instrument anytime and anywhere.
- 3 communication method options.
- Battery and external power supply method options.
- Operating temperature range (-20 ~ 70) °C.
- Fully sealed waterproof design, protection class IP67.
- High - gain antenna, multiple verification mechanisms to ensure permanent online.

Supports a high - definition LCD display screen, which cooperates with LED indicators and buttons to view temperature values, humidity values, electrical conductivity values, etc. in real time on site.

Chapter 2 technical parameter

表1 technical parameter

import	
measurand	Soil temperature, soil moisture, soil conductivity
measuring range	Soil temperature:(-40~85) °C Soil moisture: 0~100% Soil conductivity: 0~20mS/cm
performance parameter	
accuracy	soil temperature : $\pm 0.5^{\circ}\text{C}$ (0~40°C) $\pm 1.5^{\circ}\text{C}$ (-40~85°C) soil moisture : 0~100% Soil conductivity: 3%FS
resolution ratio	Soil temperature: 0.1°C Soil moisture: 0.1% Soil conductivity: 0.01mS/cm

signal transmission	LoRa network communications Support 410.125~490.125MHz band Maximum transmission power of 22dBm, maximum reception sensitivity of -147dBm, open view distance of 5KM signal coverage capability
	4G network communication, three years of traffic (100M/month) Supports MQTT, HTTP, and WES cloud service protocols LTE FDD B1/3/5/8 LTE TDD B34/38/39/40/41 (full band) Rates (Mbps) LTE FDD: 10.3 (DL)/5.1 (UL) LTE TDD: 9.1(DL)/3.1(UL)
	NB network communication, five-year traffic (300M/year) LTE Cat NB2: B3/B5/B8 Rate (kbps): Single-Tone: 25.5 (DL)/16.7 (UL) Multi-Tpne: 127(DL)/158.5(UL)
sampling period	1min~24 hours can be set
Reporting cycle	1min~24 hours can be set
Electrical specifications	

Power Supply Voltage	19000mAh, lithium battery 9~30DC, typical 24V
Battery life	Subject to the specific working conditions and reporting cycle. Collection period 30s LoRa: 8-10 years @1 time per hour NB: 4~6 years @1 time interval/hour 4G:2~3 years @1 time/h
ambient condition	
work environment	transmitter host: Temperature: (-20~70) °C , relative humidity: 5%~95% Transmitter probe: temperature : (-40~85) °C
Storage temperature	transmitter host: (-40~85) °C Transmitter probe: (-40~85) °C
levels of protection	transmitter host: IP67 Transmitter probe: IP68

Chapter 3 Product structure and size

3.1 outline dimension



图 1 Product dimensions

3.2 Connecting cable

Cable length: 5m, other lengths need to be customized.

3.3 material quality

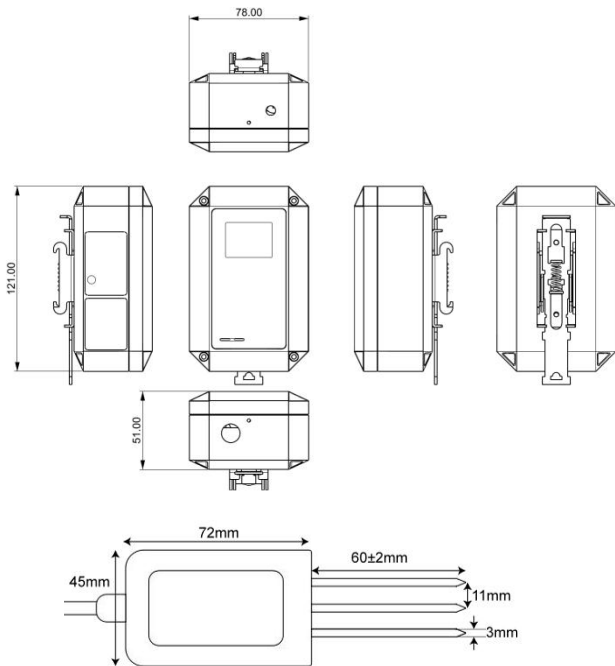
Mainframe shell material: ABS/PC

Probe shell material: epoxy resin, 316L stainless steel

Cable sheath material: polyvinyl chloride PVC or
polyurethane PU

Chapter 4 Installation and use

4.1 Inspection upon arrival

Upon receiving the product, users should first inspect its packaging. The carton must be intact with clear markings. If any visible damage is observed, immediately contact the logistics department to identify issues and determine responsibility, then notify our company. If the packaging appears undamaged, open the box to check the product's integrity.

4.2 Installation conditions

(1) When installing a three-in-one soil temperature, humidity, and conductivity transmitter, the soil temperature and humidity probe should be installed to represent the average conditions of the entire area you want to monitor for optimal measurement results. Avoid non-typical locations such as field ridges, ditch edges, fertilizer mounds, under trees, or irrigation inlets.

(2) When installing soil temperature and humidity probes, weeds, gravel, straw and other debris should be removed to expose the original soil for installation.

(3) When installing soil temperature and humidity probes,

ensure that there is no gap between the probe and the soil in the hole wall.

(4) To measure temperature, moisture content, and conductivity at deep soil layers, drill a borehole matching the target soil depth. When backfilling, carefully refill the sensor gaps with the original soil extracted during drilling and gently compact it to ensure consistency with the natural soil environment.

4.3 Installation Notes

(1) Do not force the sensor directly into hard or gravelly soil. This will cause the probe to bend or damage.

(2) If the sensor is installed in any slightly harder soil, pre-drilling is required.

(3) The depth of the sensor should be precisely corresponding to the root zone of the crop you care about or the depth specified in the monitoring plan.

(4) Wear, puncture and scratch the wire should be avoided during installation and use. If the above problems exist on site, the wire should be protected.

4.4 Installation indications



图 2 Schematic diagram of soil temperature, humidity and conductivity three-in-one transmitter probe installation



图 3 Schematic diagram of soil temperature, humidity and conductivity transmitter main body installation

4.5 Use and maintenance

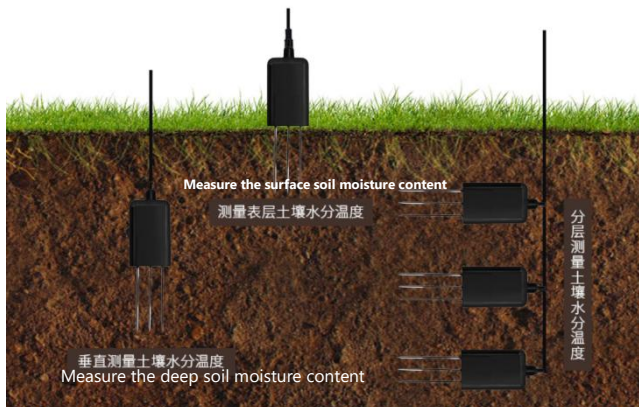
(1) The soil temperature and humidity sensor should be measured vertically to the ground, slowly pressed into the soil by hand until the sensor body is in contact with the surface. Do not use a hammer to hit it violently, so as not to damage the probe.

(2) When the sensor is not in use, clean it with water to remove dirt and debris from the probe and housing.

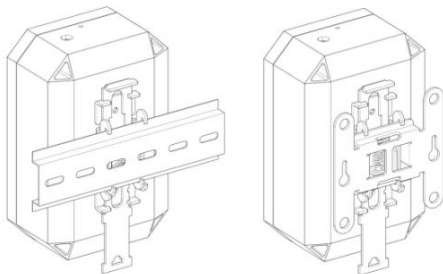
Chapter 5 operate

5.1 Display and operation unit



图 4 Panel schematic diagram

5.1.1 Interface description

表2 Interface notes

order number	explain
1	System time
2	battery capacity
3	Humidity unit
4	degree-day
5	Unit of electrical conductivity
6	Conductivity measurements
7	Humidity measurements
8	warning message
9	Temperature measurements

5.1.2 Key Instructions

One operation button on the left side of the host.

表3 Key definitions

operate	explain
click	<ol style="list-style-type: none"> 1. Light up the screen, backlight 2. Switch pages 3. List break, option switch 4. Change parameter value by 1
double	<ol style="list-style-type: none"> 1. Enter the parameter modification sub-interface

operate	explain
click	2. Make a choice
strike out	1. Identification equipment 2. Enter the parameter setting interface
Long press	Press the button for 5-6 seconds, the system light is white flashing, release the button and the device restarts.

5.1.3 Indicator light description

Communication indicator light: Green flashing, indicating normal communication

System indicator light: Green flashing, indicating normal equipment

Orange flashing indicates that the device is alarm

Red flashing indicates a device fault

5.1.4 Alarm and fault information

表4 alarm code

condition code	Problem location
1	Plate temperature
2	cell
3	PDA

condition code	Problem location
4	Uplink network
5	show
6	sensor
7	other

For example, the status code shown in the figure is 6, indicating that the sensor is alarm.

5.2 field operations

Device key operations are as follows:

Operation instructions: Click the button to light up the screen and display monitoring values and other information; click the button again to light up the backlight, and click the button again to display the QR code. In the QR code interface, click the button three times to enter the parameter setting interface.

Parameter Settings: Taking LoRa as an example, after entering the parameter setting interface, you can set parameters such as device address (Address), LORA network (Net, Channel), etc. In the Setting interface, click the button to list and line break, as shown in the figure below. Double-click the button to enter the

parameter setting interface.



图 5 Parametric interface





After entering a parameter modification interface, as shown in the  figure below , the first line shows the parameter value, indicating save, indicating return to the previous level; click the button, the operation flag is switched cyclically on four options, and when the operation flag is on a certain option, the background of that option becomes dark.



图 6 Diagram of parameter subinterface

Parameter modification example: Move the operation flag to

the first row. Double-click the button. As shown in the figure below, a triangle appears. Click the button once to increment the value by 1 , then repeat the cycle from 0 to 9. After setting  the value, double-click the button to remove the triangle. Move the operation flag back to its original position. Double-click the button again to save the settings. Move the operation flag to the designated location again. Double-click the button to return to the Settings interface.



图 7 operation chart

The page parameter table is as follows:

表5 Parameter list

page	Parameter name	span	remarks
Setting	Address	1-99	Device address (only LoRa)
	Net	1-99	LoRa network ID (only

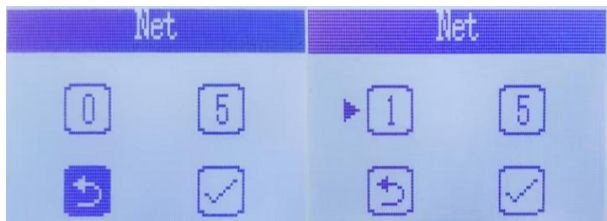
			LoRa)
	Channel	0-83	LoRa Network Channel (LoRa only)
	Exit	/	withdraw from
Address	/	1-99	Device address can be modified
Net	/	1-99	The device LoRa network ID can be modified
Channel	/	0-83	The device LoRa network channel can be modified

5.3 Devices on the cloud

This product can bind the device through "Shidian Equipment Assistant Mini Program" or web terminal to realize remote monitoring, abnormal alarm, data report and other functions.

5.3.1 Device Cloud Platform

(1) Mini Programs

Search for the applet "Shidian Equipment Assistant" in wechat and add the applet.

(2) Web end

Web address: <https://www.west-iot.com/wessass>

5.3.2 Add equipment

Step 1: Enter the device management interface of the mini program project

Click Project--Select Project--☰--Click--Click Device Management.



图 8 Enter the project equipment management interface

Step 2: Add devices

Click the + sign in the upper right corner of the device management page, select the product, and select the addition mode. You can manually add, scan the code to add, or scan the QR code to add.

Scan to add:



图 9 Add QR code to the device

Add manually:



图 10 Add manually

Bluetooth Add:



图 11 Bluetooth Add

5.3.3 Device Cloud Platform and Mini Program Usage Guide

After the device is added successfully, you can view the device in the project. Detailed operation instructions for the cloud platform and the small program can be viewed in the document center of the small program.

5.4 Device local Bluetooth configuration

Step 1: Go to the applet and search for devices with Bluetooth

Click-⊕Click to search for devices. After searching for the device you want to connect to, click stop searching.



图 12 Bluetooth search device

Step 2: Connect devices via Bluetooth

Click the device name to connect to the device.

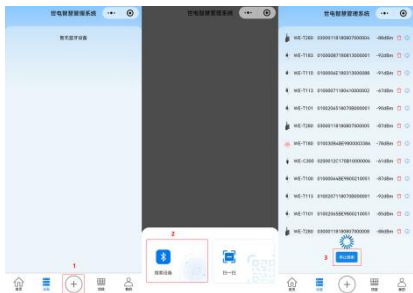

图 13 Bluetooth connected device

Step 3: Operating the equipment

After the connection is successful, you can view the device status data in the status, modify the device attributes in the

configuration, and restart, identify, and upgrade the device in the operation and maintenance.

5.5 Use Notes

This product has the function of threshold instant reporting: in the reporting cycle interval, if there is abnormal data collection (exceeding the set threshold, which needs to be set in advance), the group of data will be reported immediately (the default equipment collection cycle is 30 seconds, and the default reporting cycle is 5 minutes, which can be adjusted)

Chapter 6 Fault analysis and troubleshooting

The following table lists the possible problems and solutions of soil temperature, humidity and conductivity three-in-one transmitters. If your problem is not listed or the solution cannot deal with your problem, please contact us.

表6 Common fault analysis and troubleshooting

fault phenomenon	analysis of causes	Method of exclusion
The instrument does not display	Low battery power	Replacement of new batteries
Collection values are abnormal	Probe connector disconnected	Check whether the connection between the host and the probe is normal
Unable to receive data	The 4G/NB network can determine the status of the meter through the	(1) Correctly install the SIM card, (2) contact the network operator to set up the network, or check the signal strength of the

	<p>indicator light. If the network is not successfully stationed, check: Whether the SIM card is properly installed and whether it is in the wireless network service area.</p>	<p>local 4G network.</p>
	<p>The LoRa network is not connected</p>	<p>Check whether the supporting gateway is connected Whether the parameters of LoRa and gateway are consistent</p>
<p>The instrument does not display</p>	<p>Battery low</p>	<p>Replacement of new batteries</p>
<p>The card can't be read</p>	<p>Card not inserted/No card</p>	<p>Repaste Check your card fee</p>

	fee/bound	renewal Card untying
Platform has no data	The general procedure has a BUG	audit program

Chapter 7 Warranty and after-sales service

Our company hereby commits to customers that during the warranty period, we will provide an unconditional three guarantees service for defective products, including free repairs, replacements, or returns. All non-customized products are eligible for return within 7 days (excluding damaged or used items), while customized products shall follow the warranty terms specified in the contract.

disclaimer

During the warranty period, the following reasons for product failure are not covered by the warranty service:

- (1) Product failure caused by improper use of customers.
- (2) The customer disassembles, repairs and modifies the product by himself, resulting in product failure.

Appendix Selection and ordering

WE-T214 product selection parameters table	
Parameter	Code and specification for selection
communication mode	LR: LoRa
	4G: 4G/Cat1
	NB: NB
A accuracy class	N/A
R range ability	N/A
P power supply mode	P0: Battery power
	P1: 9~30VDC power supply
Sensor installation	N/A
Note: Customizable range and power supply mode	

instance :

WE-T214-LR-P0

LoRa soil temperature, humidity and conductivity
three-in-one transmitter, battery powered



